

## CHAPTER – 14

# SOURCES OF ENERGY

- Energy comes in different forms and one form can be converted to another. For example if we drop a plate from a height, the potential energy of the plate is converted mostly to sound energy when it hits the ground.
- If we light a candle, the process is highly exothermic so that the chemical energy of the wax is converted into heat energy and light energy on burning.

A Good Source of Energy would be one

- which has high calorific value
- be easily accessible
- be easy to store and transport
- be economical

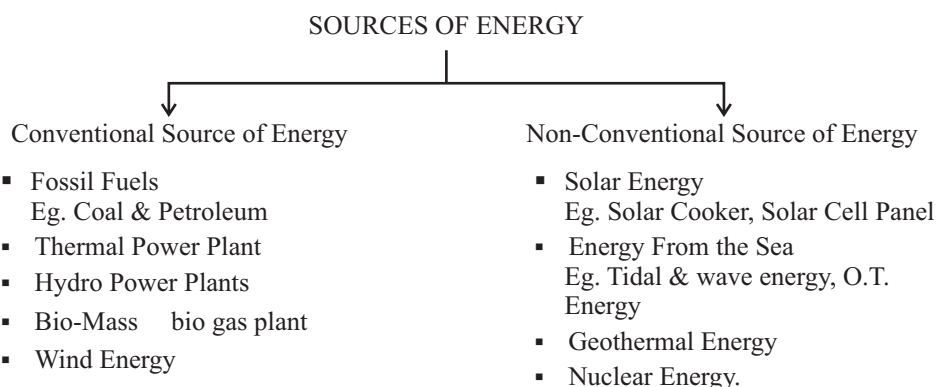

- Amongst the sources of energy, some of them get exhausted (Non-Renewable) While some of them do not get exhausted, therefore called as Renewable source of energy. Examples
  1. Non Renewable source of energy Coal, Petroleum, Natural Gas
  2. Renewable Source of energy Air, Water, Solar radiation, Geothermal Energy, ocean waves etc.

## CONVENTIONAL SOURCE OF ENERGY

### 1. Fossil Fuels : Fuels developed from the fossils. Eg. Coal & Petroleum.

- Formed over million of years ago have only limited reserves
- These are non-renewable source of energy
- India has about 6% share in the world reserved coal, that may last 250 years more at the present rate of consumption.

#### Disadvantages of Burning Fossil Fuels

- released oxides of Carbon, Nitrogen, Sulphur (acidic in nature) cause Air pollution & Acid rain & green-house effect.

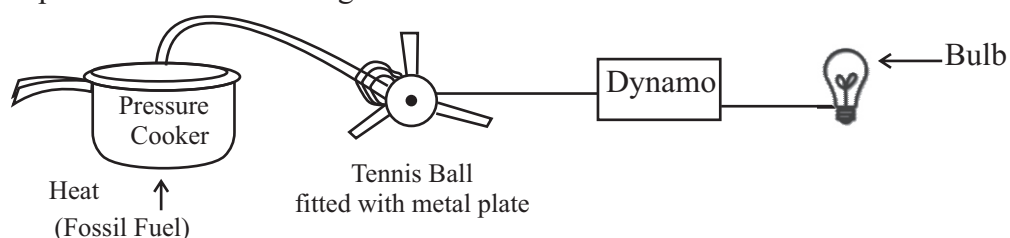

#### A Model of Thermo Electric Production.

- This is our Turbine for generating electricity. Actually the steam/fluid impart energy to rotor of turbine which can move shaft of the generator to produce electricity. A very large amount of fossil fuels are burnt in Thermal Power Plant to heat up water to produce steam.
- Hydropower Plants Convert the Potential energy of falling water into Electricity since there are few water-falls which could be used a source of potential energy, hence this is the reason, a large number of **DAMS** are built all over the world.
- Around 25% of our country's energy requirement is met by Hydro Power Plants

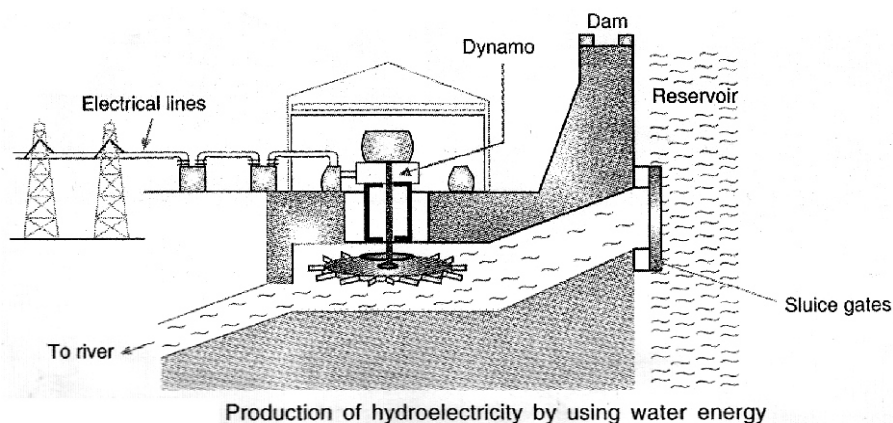

Dams are constructed to :

- Prevent flooding of river, provide water for irrigation & to generate hydroelectricity.

Disadvantages of construction of Big Dams

1. Submerging/Loss of large variety of Flora fauna and human settlements & rotting of submerged vegetation release green house gas (CH<sub>4</sub>).
  2. They pose dangers of earthquakes, landslides etc.
  3. **Biomass** is Agricultural & animal wastes that can be used as a fuel. Eg. of Biomass – Firewood, cattle dung, sewage, dry leaves, stems & bagasse.
- Normally biomass has low calorific value & produce lot of smoke when they are burnt. Their efficiency as a good fuel has been increased tremendously with the application of technology. For Eg. cowdung becomes efficient & cheap good fuel in a Bio-gas plant.
  - Charcoal is better fuel than wood because it do not contain water & other volatile material which are present in wood.

Wood  $\frac{\text{Limited}}{\text{Supply of O}_2}$  Charcoal

Charcoal burns without smoke, flames & has high calorific value.

- **Bio-gas** is an excellent fuel & contain 75% of Methane (CH<sub>4</sub>). It burns without smoke, leaves no reciters like ash, with high heat capacity.
- Biogas is produced by anerobic decomposition of the slurry (cowdung + water mixture) by microbes. This process is applied in a Bio gas plant.

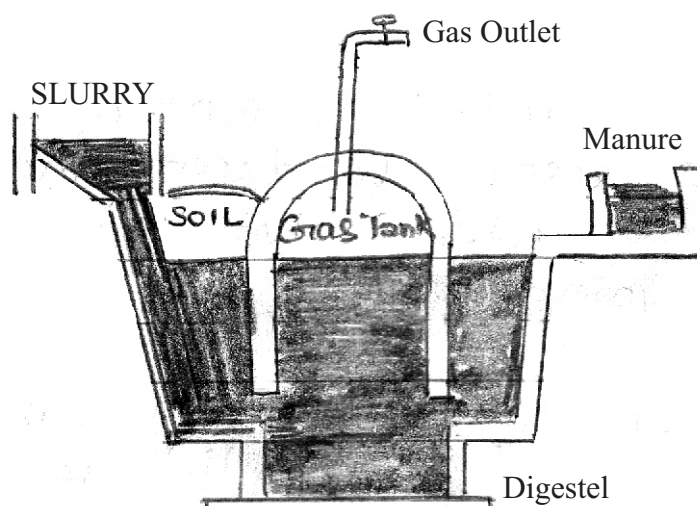

- The Biogas is stored in the gas tank from which they are drawn through pipes for use in a Bio-gas plant
- Bio gas is used for lighting, cooking in the rural areas. While the slurry left behind is used as excellent manure, rich in nitrogen and phosphorous
- The large scale use of Bio-wastes & sewage material provide a safe and efficient method of waste-disposal besides supplying energy and manure.

### **WIND ENERGY**

- Unequal heating of the landmass and water bodies by solar radiation generates air movement & causes winds to blow. This kinetic energy of the wind can be used to do work.
- This energy is utilised to lift water from the well & to generate electricity in the wind mill.

Actually the rotatory motion of the windmill is used to turn the rotor of the turbine which then generate electricity through Dynamo.

The output of a single windmill is quite small so a number of windmills are erected over a large area - called wind energy farm.

India Ranked Fifth in the world in harnessing wind energy for the production of electricity. It is estimated that nearly 45,000 MW of electric power can be generated if India's wind potential is fully exploited.

- The minimum wind speed for wind mill to serve as a source of energy is 20KMPH.

#### **Advantages of Wind Energy**

1. Eco friendly
2. Efficient source of renewable energy.
3. No recurring expenses for production of electricity

#### **Limitations of Wind Energy**

1. Wind energy farms need large area of land
2. Difficulty in getting regular wind speed of 15-20 KmPH.
3. Initial cost of establishing wind energy farm is very high.
4. High level of maintenance of blades of wind mill.

### **Non Conventional Sources of Energy**

#### **Solar Energy :**

The energy imitted by the sun in form of heat and light is called solar energy.

Solar Constant =  $1.4 \text{ kJ/s m}^2$

Outer edge of the earth receives solar energy equal to  $1.4 \text{ kJ/sm}^2$  which is known as solar constant.

### Solar energy devices :

A large number of devices that utilize solar energy directly like :

- (i) Solar Cooker
- (ii) Solar furnaces
- (iii) Solar cells
- (iv) Solar water heaters

### Solar heating devices :

- Use black painted surface because black surface absorbs more heat as compared to white or other surface.
- Use of glass plate because it allows shorter infrared radiations to pass through it but doesn't allow the longer wavelength infrared radiations to through it, that results in increase in temperature.

### Solar Cooker :

#### Box type solar Cooker

- It consists of a rectangular box which is made up of material such as plastic or wood.
- Box is covered with black sheet and its inner walls are painted black to increase heat absorption.
- Solar cookers are covered with glass plate and have mirros to focus the rays of the sun and achieve a higher temperature.

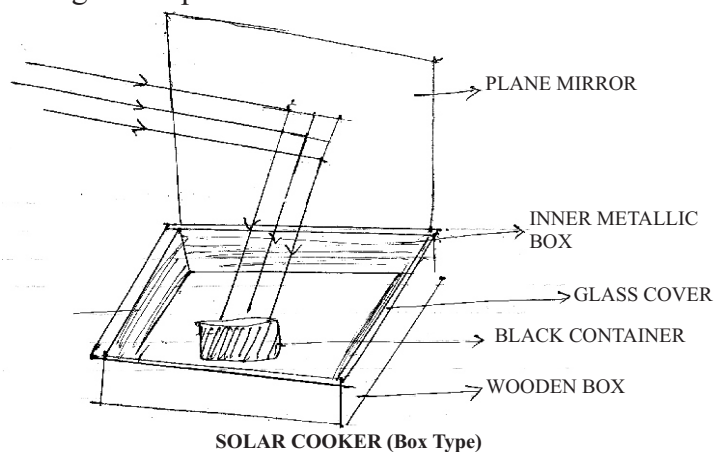

**Advantages :**

1. Use energy which is available in plenty (Solar Energy)
2. Is pollution free.
3. More than one food can be cooked simultaneously

**Disadvantages :**

1. Cannot be used for frying or baking purpose.
2. Food cannot be cooked at night or on a cloudy day.
3. Direction of reflector of solar heating has to be changed from time to time to keep it facing the sun

**Solar Cells :**

- Solar cells are device that convert Solar energy into electricity.
- Develops a voltage of 0.5 – IV and can produce about 0.7W of electricity.

**Advantages of Solar Cell**

1. Require a little maintenance
2. Have no moving part.
3. No focussing device is required
4. Can be set up in remote areas.
5. Environment - friendly i.e. do not cause pollution.

**Disadvantage of Solar Cells**

1. It require high cost
2. Efficiency is low
3. Initial cost of installation is quite high.

**Uses of Solar Cell**

1. Used in calculators, watches etc.
2. Used in artificial satellites and space probes.
3. It is used in radio or wireless transmission system.

**Solar Panel**

A large number of Solar Cells connected to each other in an arrangement is called solar panel.

**Material used for making solar cells**

- Silicon  
Silver is used for inter connection of cells.

## Energy from the Sea or Ocean

The energy from the sea is available in the following forms.

- (i) Energy of sea waves
- (ii) Tidal energy
- (iii) Ocean Thermal Energy.

### (i) Energy of Sea Waves

- The waves are generated by the strong winds that blows across the sea.
- The kinetic energy of this moving water rotates the turbine of a generator

### Limitation

When strong winds stop blowing, the generator stops producing electricity

### (iii) Tidal Energy

- The tidal energy possessed by water during tides.
- The tides are caused due to gravitational force of attraction exerted by the moon on the water of the ocean.
- This form of energy is harnessed by constructing a dam across a narrow opening to the sea.
- A turbine fixed at the opening of the dam converts tidal energy to electricity.

### (iii) Ocean Thermal Energy

The power plants used to harness the ocean thermal energy is known as “Ocean Thermal Energy Conversion plant) (OTEC)

- Temperature difference between surface water and water at the depth of 2km should be 20°C or more.
- The warm surface water is used to boil ammonia (liquid)
- The vapours of the liquid are used to run the turbine of generator.
- The cold water (from deeper layers) is pumped up to condense the vapour into liquid.

### Geothermal Energy

1. Energy stored as heat inside the earth
2. The steam of underground water is taken out by sinking pipes through holes drilled in the earth’s crust. The steam under high pressure is used to rotate the turbines of the generator to produce electricity.

## Nuclear Energy

- Nuclear energy is the energy which is stored in the nucleus of an atom.
- Nuclear energy is of two types
  - (i) **Nuclear fission** nucleus of a heavy atom (Uranium) when bombarded with low energy neutron split (break down) into lighter nuclei and huge amount of energy is released
  - (ii) **Nuclear Fusion** When two lighter nuclei join up to form heavy nucleus and tremendous amount of energy is released.
- Nuclear fission process is utilized in nuclear reactors to produce electricity.
- Major Nuclear power plants : Tarapur, Rana Pratap Sagar, Kalpakkam.

### Advantages of Nuclear Energy :

1. Large amount of energy is released.
2. In nuclear power plant, the nuclear fuel is inserted once to get energy over a long period of time.

### Disadvantages of Nuclear Energy :

1. High cost of installation.
2. Environmental contamination may occur due to improper nuclear waste disposal.

## Environmental Consequences

1. Energy sources should be used judiciously otherwise it would disturb the environment.
2. Use of clean fuels like CNG (compressed natural gas) because burning of fossil fuel causes green house effect.
3. Assembly of devices like solar cell (otherwise renewable source of energy) would have caused environmental damage.

### How long will energy source last

the sources of energy can be divided into two categories :

- (i) Renewable sources of energy eg wind, sun, biogas
- (ii) Non renewable sources of energy eg. Coal, Petroleum, Natural Gas.

Continuous use of non renewable source of energy is a matter of concern because ultimately the deposit of these sources will be completely finished on the other hand renewable sources of energy will last forever eg sun as a source of energy will be available for a very long period of time.



## **EXERCISE**

### **(Question Bank)**

#### **Very Short Answers (1 Mark)**

1. What is a good source of energy.
2. Expand CNG and LPG
3. What is the minimum wind velocity required to obtain useful energy with a wind mill?
4. Name the main constituent of biogas.
5. Give two examples of fossil fuels
6. Name the device which directly converts solar energy into electric energy.
7. What does "OTEC" stand for?
8. What is nuclear energy?
9. Which one out of these is renewable source of energy solar energy, coal, petroleum, bio gas.
10. Which source of energy would you use to heat your food and why?

#### **Short Answers (2 or 3 Marks)**

1. State two disadvantages of using fossil fuels as a source of energy.
2. Write two disadvantages of constructing high rising dams.
3. Give (i) two limitations and (ii) two advantages of wind mill.
4. Name any three forms of energy of the oceans which can be converted into usable energy forms. Describe how it is done in each case.
5. Explain the working of biogas plant with the help of labelled diagram
6. Explain the principle on which the solar cooker works.
7. Write the advantages and disadvantages of using a solar cooker.
8. How does hydro electric power plant operate? Draw diagram

#### **Long Answer Type Questions (5 Marks)**

1. (a) Why is the solar cooker box covered with plane glass plate?  
(b) Why is nuclear fission reaction considered better.  
(c) Use of wood as a domestic fuel is not considered as good. State two reasons for it
2. Distinguish between renewable and non renewable sources of energy? Which one of them you consider as better? Why?